

## **Chapter-1**

# **Project Management Skill: PERT and CPM Techniques**

---

Project Management is valuable as a means to define a project and its tasks and to provide a common platform to sing same tune of music for workers, stakeholders and managers alike. Project management involves decision making for the planning, organizing, coordination, monitoring and control of a number of interrelated time bound activities. It is a wonderful way to get with all the forces involved to ask and answer a hard question: is this the goal we are trying to meet and is the price worth the goal? It is a very good way to identify the requirements and risks of a project long before a project is started or even agreed upon. Project Manager therefore, often depends on tools and techniques that are effective enough not only for drawing-up the best possible initial plan but also capable of projecting instantaneously the impact of deviations so as to initiate necessary corrective measures.

The first standardized approach to Project Management was crafted by Henry Gantt with the introduction of Gantt charts that showed task durations and a crude (but not intuitive) relationship between tasks. In 1917, Mr. Gantt devised a technique (the Gantt chart) that organized tasks in a visual and logical manner that made it easier to get a snapshot of the progress of the tasks individually and the project as a whole. It is a pictorial representation specifying the start and finish time for various tasks to be performed in a

project on a horizontal time scale. A sample Gantt chart is shown in fig. 1.

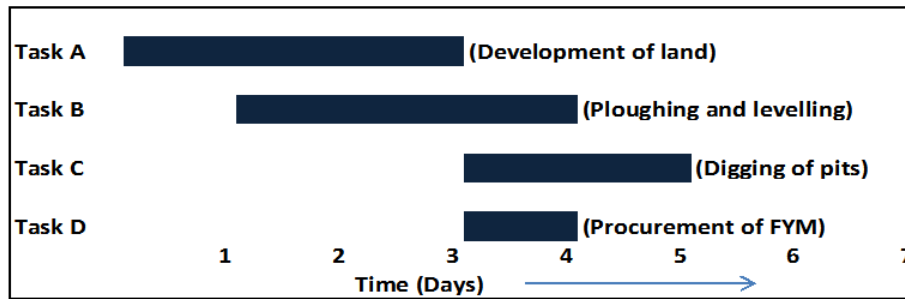

**Fig. 1: Sample Gantt chart**

In this fig. “Task A” is development of land, “Task B” is ploughing and leveling etc. Land development of land (Task A) takes three days starting from day one. However in practice the time scale is superimposed on a calendar i.e., if land preparation starts on 1st September it would be completed by 3<sup>rd</sup> September.

#### **Advantages of Gantt chart**

- Gantt charts are quite commonly used. They provide an easy graphical representation of when activities (might) take place.

#### **Limitations of Gantt chart**

- Do not clearly indicate details regarding the progress of activities
- Do not give a clear indication of interrelationship between the separate activities

#### **Networks**

The network is a logical extension of Gantt’s milestone chart incorporating the modifications so as to illustrate interrelationship between and among all the milestones in an entire project. The two best-known techniques for network analysis are Programme Evaluation and Review Technique (PERT) and Critical Path Method (CPM).

### **Programme Evaluation and Review Technique (PERT)**

The U.S. Navy, plagued by cost and time overruns in the Polaris Submarine program, created PERT (Program Evaluation and Review Technique) in 1958. PERT is a technique that requires clear scope definition and optimistic, pessimistic and most likely duration estimates for every task and the project as a whole. By creating a logical sequence of tasks, each with its own duration estimates, PERT provided a more realistic estimate of the probable task (and project) durations.

In PERT activities are shown as a network of precedence relationships using activity-on-arrow network construction with multiple time estimates and probabilistic activity times.

**USED IN:** Project management - for non-repetitive jobs (research and development work), where the time and cost estimates tend to be quite uncertain. This technique uses probabilistic time estimates.

#### **Steps in PERT**

1. Identify the specific activities and milestones.
2. Determine the proper sequence of the activities.
3. Construct a network diagram.
4. Estimate the time required for each activity.
5. Determine the critical path.
6. Update the PERT chart as the project progresses.

#### **PERT terminology**

Lucid and simple description of the various concepts and terms related to PERT has been made by Venkatswarlu (1993). Some of the terms frequently used in PERT are as follows.

**Activity:** A recognizable work item of a project requiring time and resource for its completion. any activity, which needs some resources-

money, men, materials for accomplishing in a specified time. It is denoted by ‘

### Use of nodes and arrows in activity

- **Arrows** → An arrow leads from tail to head directionally. It indicates ‘ACTIVITY’, a time consuming effort that is required to perform a part of the work.
- **Nodes** ○ A node is represented by a circle. It indicates ‘EVENT’, a point in time where one or more activities start and/or finish. A completion of an activity is represented by a node.
- An arrow represents a task, while a node is the completion of a task.

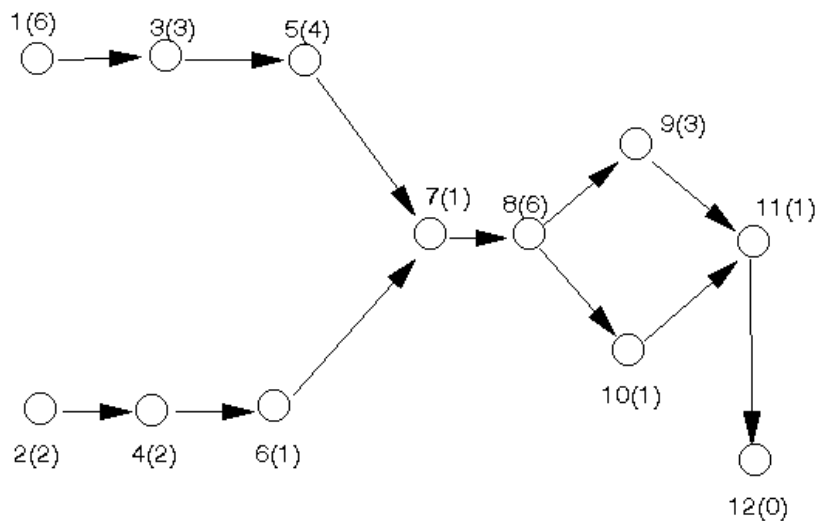

**Fig. 2: Example of nodes and arrows**

- **Dummy Activity:** An activity that indicates precedence relationship and requires neither time nor resource. It is logical relationship between activities and does not require any resources

## Dummy Activity

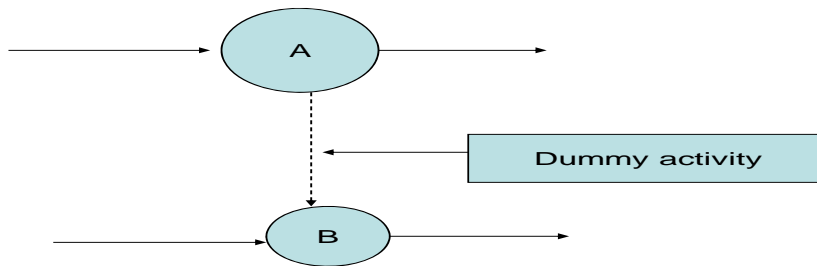

**Fig. 3: Dummy activity**

**Critical Activity:** The longest time path connecting the critical activities in the project network. The total time on this path is the shortest duration of the project. Activities on the critical path having zero slack / float time.

**Event:** An instantaneous point in time signifying completion or beginning of an activity. It represents definite state in the progress of the project. It does not consume time. It is usually denoted by a circle divided into two equal halves (Fig. 4). The left half is generally used to denote the event number. The right half is further divided into two halves and the top represents Earliest Starting Time (EST) and the bottom the Latest Starting Time (LST) as shown in the fig. below.

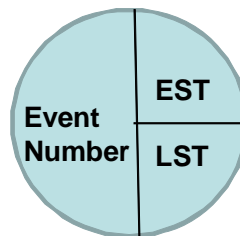

**Fig. 4: Event**

**Earliest Start Time (EST):** The earliest possible time at which the event can occur. The EST also denotes the Earliest Start Time (EST) of an activity as activities emanate from events. The EST of an activity is the time before which it cannot commence without affecting the immediate preceding activity.

**Latest Start Time (LST):** The latest time at which the event can take place. Also referred as the Latest Start Time (LST) indicating the latest time at which an activity can begin without delaying the project completion time.

**Slack:** The amount of spare time available between completion of an activity and beginning of next activity.

**Activity Slack (AS):** It is the slack associated with an activity. It is computed by using the following formula:

$AS = LST \text{ of end event} - EST \text{ of starting event} - \text{Duration of reference activity.}$

**Event Slack (ES)=** It is the slack time associated with an event. It is obtained with following simple formula:

$ES = LST - EST$

**Burst Event:** An event which gives rise to more than one activity (Fig. 5).

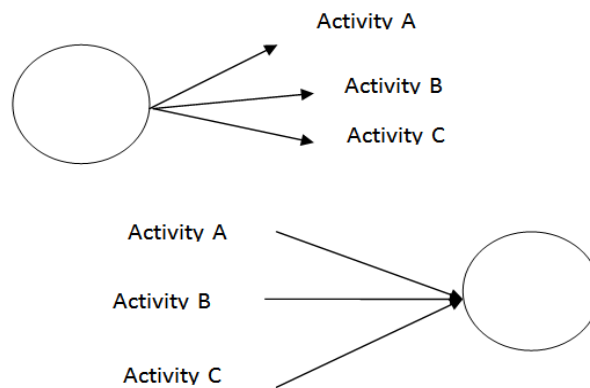

**Fig. 5: Burst Event**

**Merge Event:** The event which occurs only when more than one activity are accomplished (Fig. 6).

**Fig. 6. Merge Event**

**Expected Time:** The weighted average of the estimated optimistic, most likely and pessimistic time duration of a project activity:

$$\bullet \quad t_e = \frac{T_0 + 4T_m + T_p}{6}$$

Whereas,

$t_e$ - expected time

$T_0$ = optimistic time ,(minimum time assuming everything goes well)

$T_m$ = most likely time, (modal time required under normal circumstances)

$T_p$ = pessimistic time,(maximum time assuming everything goes wrong)

**Merits of PERT**

- It is a basic time control device for a project
- Guiding and supervision can be extended for execution of various activities.
- Monitoring can be done for many project

**Demerits of PERT**

- If time estimates are not realistic then the entire project duration may go wrong.
- For routine planning and recurring events PERT is not useful

- It does not consider the resources for accomplishing various activities.

### **Critical Path Method (CPM)**

CPM was developed by M.R. Walker of DuPont and J.E. Walker of Remington Rand in 1957. The emphasis was the trade-off between the cost of the project and its overall completion time e.g. for some activities, completion time may be decreased by spending more money. How does this affect the overall completion time of the project? Unlike PERT, CPM is a deterministic model – based on the concept that previous events, not probability, determine events. Like PERT, CPM identifies a critical path of tasks (hence the name) that reflect the longest path through the network of tasks. Unlike PERT, CPM analyzes only the longest chain of critical tasks. These critical tasks determine the overall length of the project. If these tasks can be shortened, the project will be shortened; tasks not on this critical path will have no effect on the project duration. Unlike PERT, CPM places value on the sequence of events and do not recognize other variables. In a very simplified paraphrase, CPM states that if task A takes 5 units, task B takes 3 units, and task C takes 8 units, the project will take 16 units. CPM accounts for task in sequence and is useful in easily determining bottleneck points or areas that can be manipulated for improving the speed of project completion (crashing).

**USED IN:** Production management - for the jobs of repetitive in nature where the activity time estimates can be predicted with considerable certainty due to the existence of past experience.

CPM Seeks to examine the consequences of crashing of total cost and relationships between total direct cost and project duration. It has the main assumption that a)Activities can be crashed for their



implementation and b) crashing reduces time but leads to enhance direct cost

$$\text{Cost to crash per day/week} = \frac{\text{Crash cost} - \text{Normal cost}}{\text{Normal time} - \text{Crash time}}$$

Because they share similarities, PERT and CPM can be (and frequently are) used together. PERT and CPM both assume that a small set of activities, which make up the longest path through the activity network control the entire project. PERT and CPM also share six key assumptions:

- 1) All tasks have distinct begin and end points
- 2) All estimates can be mathematically derived
- 3) Tasks must be able to be arranged in a defined sequence that produces a pre-defined result
- 4) Resources may be shifted to meet need
- 5) Cost and time share a direct relationship (Cost of each activity is evenly spread over time)
- 6) Time, of itself, has no value

When used together, PERT and CPM can provide:

- 1) A range of time estimates (PERT)
- 2) Likely time estimates (PERT and CPM)
- 3) Cost estimates (CPM)
- 4) Time and costs if crashed (CPM)
- 5) Probabilities of completion on time for a range of times (PERT)
- 6) A clear path of tasks that are critical to the project (PERT and CPM)
- 7) A central focus for solid communications on project issues (PERT and CPM)

### **Steps for Network Analysis**

The six steps of network analysis are as follows.

- 1) Prepare the list of activities
- 2) Define the inter relationship among the activities
- 3) Estimate the activity duration
- 4) Assemble the activities in the form of a flow diagram
- 5) Draw the network
- 6) Analyze the network i.e. compute EST and LST; identify critical events, critical path and critical activities.

### **Step-1. Prepare the list of activities**

The total project is subdivided into activities and each activity is given an alphabetical symbol / code. For example in the activities of a pineapple plantation project could be broken down into number of activities as listed in Table no. 1 given below.

**Table 1: List of activities**

<b>Sl. No.</b>	<b>Activity</b>	<b>Symbol/ Code</b>
1.	Development of land	A
2.	Ploughing and leveling of plot	B
3.	Digging of pits	C
4.	Procurement of FYM	D
5.	Purchase of crown	E
6.	Application of FYM	F
7.	Transplanting of crown	G

### **Step 2: Define the inter relationship among the activities**

The next step is to define the inter relationship between the activities required to execute the project. It may be done by specifying the preceding and succeeding activity. Preceding activity for an activity is its immediate predecessor, i.e. the activity that needs to be completed before the start of the new activity. In the given example, selection of site precedes ploughing and leveling of plot. The inter relationship among the activities listed in the example is as in Table 2.

<b>Sl. No.</b>	<b>Activity</b>	<b>Symbol/ Code</b>	<b>Preceding activity</b>
1.	Selection of site	A	-
2.	Ploughing and leveling of plot	B	A

3.	Digging of pits	C	B
4.	Procurement of FYM	D	B
5.	Purchase of crown	E	B
6.	Application of FYM	F	B, C
7.	Transplanting of crown	G	E,F

**Step 3. Estimate the activity duration**

The third step is to determine the expected time to execute each and every activity. The expected time need to be calculated by using the above said formula

$$te = \frac{T0+4Tm+Tp}{6}$$

Example: Estimation of estimated time for the activity “selection of site”

For this activity the three time estimates i.e., Optimistic (To), Most likely(Tm) and Pessimistic times (Tp) are 2, 5 and 10 days respectively.

i.e. TO = 1, TM = 3, and TP = 4. TE = (2 + 4\*3 + 4 = 2+12+4)/6 = 18/6 = 3 days

Three time estimates, optimistic, pessimistic and most likely, could the decided through focus group discussion based on past experiences in execution of similar activities or from the feedback from individuals with relevance experience. The three time estimates and computed estimated time for the project activities are given in Table 3.

**Table 3. Estimated time for the activity**

Sl. No.	Activity	Symbol	Preceding activity	Estimated time
1.	Selection of site	A	-	3
2.	Ploughing and leveling of plot	B	A	2
3.	Digging of pits	C	B	4
4.	Procurement of FYM	D	B	2
5.	Purchase of crown	E	B	7
6.	Application of FYM	F	B, C	2
7.	Transplanting of crown	G	E,F	3

**Step 4. Assemble the activities in the form of a flow diagram**

In a flow chart the activity and its duration is shown in a box. The boxes are connected with lines according to the preceding and succeeding activity relationship as shown in the Fig. 7 below. The longest path in the chart is the critical path.

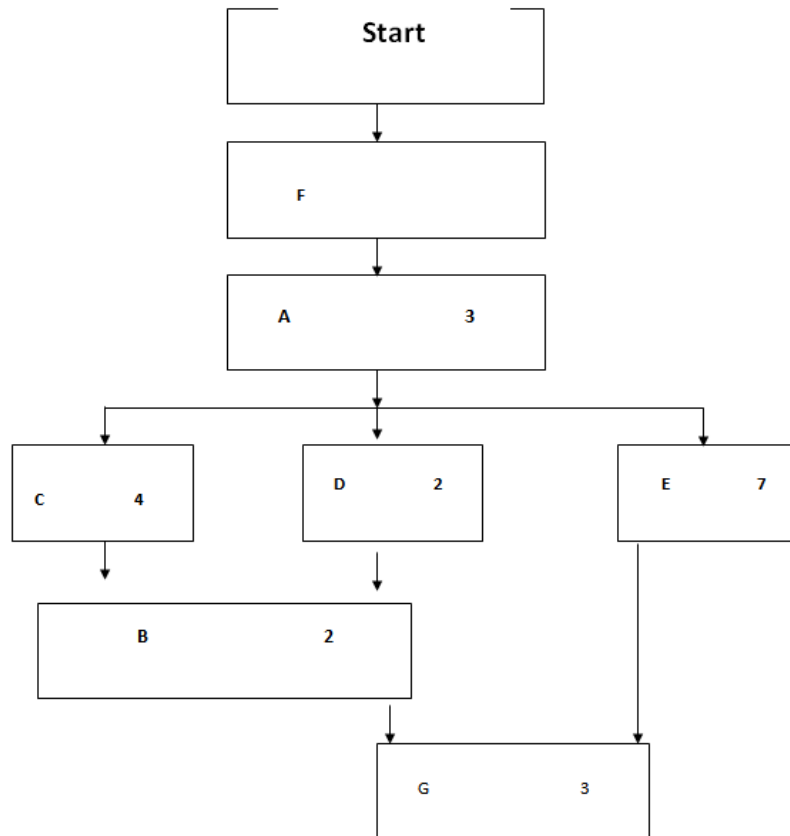

**Fig. 7: Flow chart of the activities**

**Path I A-B-C-F-G  $3+2+4+2+3=14$  days**

**Path II A-B-D-F-G  $3+2+2+2+3= 12$  days**

**Path III A-B-E-G  $3+2+7+3= 15$  days**

The path Path III i.e., A-B-E-G being the longest path (15 days) is the critical path.

**Step 5. Draw the network**

In this step the graphical representation of the project is generally presented with the precedence relationship among the activities.

**Rules for Drawing the Network:**

- 1) Each activity is represented by one and only one arrow in the network
- 2) All the arrows must run from left to right.
- 3) Dotted line arrows represent dummy activities.
- 4) A circle represents an event.
- 5) Every activity starts and ends with an event.
- 6) No two activities can be identified by the same head and tail event.
- 7) Do not use dummy activity unless required to reflect the logic.
- 8) Avoid Looping and crossing of activity arrows by repositioning.
- 9) Every Activity, except the first and the last, must have at least one preceding and one succeeding activity.
- 10) Dangers, isolated activities must be avoided.
- 11) For coding use alphabets for all activities including the dummy activity and numbers for events.

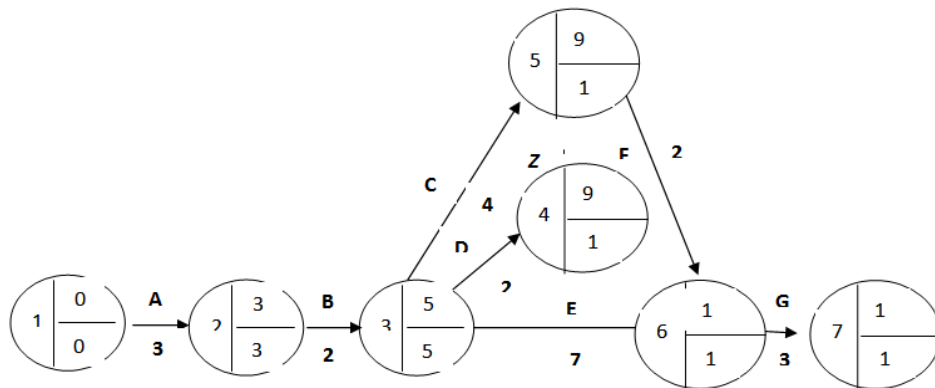

**Fig. 8: Network diagram**

**Step 6. Analyze the network i.e. compute EST and LST; identify critical events, critical path and critical activities.**

The EST represents the time before which the activity cannot begin and LST refers to the latest time by which the activity must begin. The EST and LST are computed in two phases. The EST is calculated first in the forward pass beginning from the start event. For the start event the EST is always set to zero so that it can be scaled to any convenient calendar date at a later stage. The EST at the last event is generally considered to be the project duration i.e. the minimum time required for project completion. Therefore, EST and LST are equal at the end event. LST for other events is then calculated through backward pass starting from the end event. Table 4 presented below showing the computation of EST and LST.

Sl. No.	Activity	Duration	Preceding event	Succeeding event	EST	LST	Critical Activity
1.	A	3	1	2	4	4	A
2.	B	2	2	3	5	5	B
3.	C	4	3	5	9	10	-
4.	D	2	3	4	9	10	-
5.	E	7	3	6	12	12	E
6.	F	2	5	6	9	10	-
7.	G	3	6	7	15	15	G

**Project Duration =15 days (A-B-E-G is critical path)**

**Critical Path and Project Management:**

The critical path time being the shortest project time any delay in completion of any of the activity on the critical path would delay the entire project. Therefore it is the critical activity that needs to be monitored for timely completion of the project. However, the activities with positive event slack could be rescheduled within the available time frame for efficient utilization i.e. smoothing of the demand on the available resources. If the duration of the project requires to be reduced, activities on the critical path will be the ones to be

considered for completion at an early date with allocation of additional resources.

PERT and CPM share several weaknesses that add to the PM controversy. Both consider only causal dependencies, where 1 task must be completed before another can begin (have to bake bread before you can make a sandwich). Other dependencies, such as resource dependencies, where a task is limited by availability of resources (more bread can be baked by 2 bakers, but only 1 is available) or discretionary dependencies (optional task sequence preferences that, though not required, may reflect organizational preferences) are not considered. The range of assumptions required for PERT and CPM to be effective, and the lack of acknowledgement of dependencies, has led to newer PM theories which are not mainstream and are considered experimental.

### **Reference**

- [1] Venkateswarlu, K. and Raman, K.V.(1993). Project Management Techniques for R&D in Agriculture, Sterling Publishers Private Ltd.